



DAN

OIL SERVICES COMPANY

COMPANY PROFILE DRILLING DIVISION

YOU TARGET  **YOUR GOAL**
WE HELP YOU ACHIEVE IT

Company Profile

Executive Summary

Established in March 2026 in Tripoli, Libya, DAN Oil Service is a privately held Libyan company dedicated to setting new benchmarks in the oil and gas sector.

We specialize in providing high technical solutions with a focus on safety, innovation, and local expertise.



Our Vision & Mission

Our Vision

To become the premier Libyan Oil Services provider, recognized as the first choice for excellence and reliability within the national Oil and Gas industry.



Our Mission

To provide unparalleled inspection, testing, and maintenance services. We are committed to ensuring the integrity and reliability of critical equipment and infrastructure, empowering the oil and gas industry to operate at peak efficiency.



Our core business values are:

Our operations are guided by five fundamental pillars that define our corporate identity:

HSE as a Priority: The well-being of our employees, contractors, third-party personnel, and the environment is the pinnacle of our daily operations.

Quality Obsession: We combine cutting edge technology with experienced management systems. Our success is measured solely by client satisfaction and our ability to adapt to emerging technologies.

People Driven Success: The passion and drive of our workforce are the cornerstones of our corporate achievements.

Strategic Alliances: Through smart technical partnerships, we accelerate innovation, expand Libyan market reach, and optimize resources. These collaborations allow us to leverage complementary strengths, such as specialized knowledge and infrastructure, to bring advanced products to market faster while reducing development risks

DAN Oil Service Services

DAN Oil Service is organized into specialized divisions designed to provide comprehensive support across the full lifecycle of oilfield operations:

1. **Drilling Services & Technology:** Deploying advanced methods and technical solutions to optimize drilling efficiency.
2. **Fishing & Downhole Services:** Expert intervention and retrieval services to manage wellbore challenges.
3. **Well Testing Services:** Accurate data acquisition and analysis to evaluate reservoir performance.
4. **Slickline Services:** Precise mechanical well intervention for maintenance and instrumentation.
5. **Pumping Services:** Full-scale support for cementing and coiled tubing operations.
6. **Supply Chain Services:** Supply chain services encompass the end-to-end management of goods, typically structured around six key components: planning, sourcing, manufacturing, warehousing, distribution, and returns
7. **Inspection Services:** Specialized inspection of drill pipes, casing, and pipelines, as well as the certification and assessment of valves and Christmas trees to ensure operational integrity.
8. **Maintenance & Technical Support:** Proactive and corrective services to ensure the continuous reliability of oilfield equipment.
9. **Wireline Services:** we had partnership with Eastern United Petroleum Services.



Why Partner with Us?

At DAN Oil Service, we believe that systematic implementation of our values makes us worthy of our clients' confidence. We don't just aim to achieve trust, we strive to maintain it through every day, every project.

Current Investments in Libya

DAN Oil Services has invested in brand new drilling services. The first base will be located in 103 Field and the second one in Almamura 50km west of Tripoli Libya.

The base will contain the following facilities:

- ❖ 1100 sqm hanger equipment with a new 10 ton overhead crane, 90 sqm environmentally compliant wash bay, Brand new computerized break out units, PDM test flow loop which is unique capability that DAN Oil Services enjoys in Libya.
- ❖ Electronic Lab.
- ❖ New Jar Tester for drilling Machine.
- ❖ Storage rack for Drilling Equipment.
- ❖ Welding/ Grinding area.
- ❖ Storage yard of 8000 sqm.
- ❖ Offices/Conference rooms.

Furthermore, DAN Oil Services has invested in recruiting and hiring top notch talent, both technical and support staff.



DAN Oil Services Organization Chart

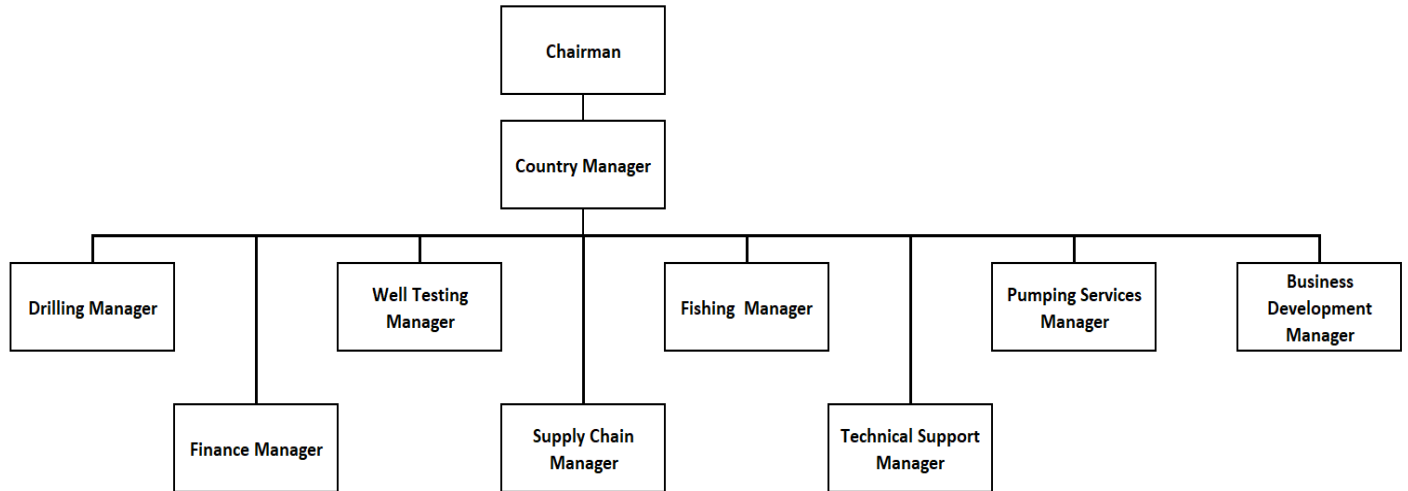

Company Divisions

Drilling Services

- **Positives Displacement Motors**

DAN Oil Services is planning to have more than 24 downhole motors for all sizes. The motors available will be from sizes from 6 ½” to 9 5/8” diameters for various hole sizes.

- **Teledrift Technology: (Deviation Measurement While Drilling)**

This is a unique service just introduced to Libya in March 2008 by our partner Al-Mothouka Oilfield Services. This technology provides instantaneous deviation measurement while drilling saving operators considerable rig time and minimizing stuck pipe risks. Through our technical alliance with Teledrift, Oklahoma, USA we are the sole provider of this service in the North Africa.

- **MWD Service**

DAN Oil Services Plan to have 4 MWD sets with Complete maintenance facilities from APS technologies in Houston Texas.

- **Equipment Rental**

DAN Oil Services is planning to have Drilling Jars, Shock Tools and other drilling equipment like stabilizer Monal and reamers for all hole sizes and we will have the capacity to service all our equipment in our facilities which result in quick turnaround time on this equipment.

Fishing Services

Our vision for fishing services to be the top industry leading fishing company in the country.

DAN Oil Services will provide a full range of fishing solutions combined with cutting-edge technology to address the challenges faced throughout every stage of a wellbore's lifecycle start from drilling and completions to production. Our extensive selection of specialized fishing tools, combined with our expert team, will be enable us to support a full spectrum of applications, from simple recovery operations to complex interventions in cased-hole, open-hole, and thru-tubing intervention.

Our Solutions

- Internal Catching Fishing
- External Catching Fishing
- Casing Exit
- Abandonment and Remedials
- Milling
- Thru Tubing Fishing & Milling

Equipment and Resources

- Fishing Tools
- Stroking Equipment
- Junks Retrieval
- Milling Equipment
- Casing Exit Equipment (Cased & Open Hole Whipstock)
- Thru Tubing Equipment (Motors, Jars, Mills, fishing tools)
- Plugs and Packers

Slickline Services

Slickline Services – Advanced Well Intervention Capabilities

Our slickline services will cover a wide spectrum of operations, including routine, advanced, and contingency interventions:

Well Intervention & Completion Support

- Gauge cutter and drift run for tubing integrity verification
- Setting, retrieving, and shifting of:
 - Lock mandrels (various profiles)
 - Blanking and bridge plugs
 - Standing and check valves
 - Gas lift valves (GLV installation, replacement, and optimization)
- Deployment of completion accessories and downhole tools

Advanced Downhole Operations

- Nipple profiling and precise depth correlation
- Multi-depth memory gauge surveys (pressure & temperature)
- Pressure gradient and reservoir profiling
- Mechanical jarring operations (impact tools and controlled release)

Well Integrity & Clean-Out Services

- Leak detection support through pressure diagnostics
- Sand, scale, and debris removal using specialized bailers
- Mechanical paraffin removal
- Wellbore clean-out and conditioning operations

Fishing & Remedial Operations

- Recovery of stuck, lost, or broken downhole equipment
- Advanced fishing using overshots, spears, and retrieval tools
- Stuck tool release using controlled jarring techniques.

Production Optimization

- Sliding sleeve shifting (zone control and production tuning)
- Gas lift valve optimization and troubleshooting
- Zonal isolation and well control solutions

Well Testing Services

Well Testing & Surface Facilities – Flexible & Scalable

We plan to provide complete surface well testing solutions designed for both evaluation and production support:

Production Testing & Flowback

- Well clean-up and controlled flowback operations
- Accurate measurement of oil, gas, and water production rates
- Fluid characterization (GOR, BS&W, and phase behavior analysis)

Separator & Surface Equipment Operations

- Operation of 2-phase and 3-phase separators under variable conditions
- Handling high gas-to-liquid ratio (G/L) wells
- Sand management and separation during flowback
- Integration of heating systems (when required) to enhance separation efficiency

Early Production Facility (EPF / E.B.F Capability)

- Capability to convert separator units into Early Production Facilities (EPF / E.B.F)
- Temporary production systems including:
 - Separation
 - Storage
 - Controlled export to tanks or pipelines
- Accelerated production startup without dependency on permanent facilities
- Significant reduction in **Time to First Oil (TFO)** and early revenue generation

Flow Control & Surface Management

- Choke manifold operations (manual and adjustable)
- High-pressure flowline rig-up and well control
- Surge tank and buffer tank management

Data Acquisition & Reservoir Evaluation

- Real-time monitoring of pressure, temperature, and flow rates
- Build-up and drawdown testing
- Extended Well Testing (EWT) for long-term reservoir evaluation

HSE & Environmental Compliance

- Flare operations with safe gas handling
- Emergency shutdown (ESD) systems readiness
- Full compliance with H2S safety procedures
- Strict adherence to international HSE standards

Pumping services (Cementing & Coiled tubing Services)

These services will be added to our services in near future

Supply chain Service

A comprehensive supply chain offering End-to-End journey.

- **Strategic Sourcing & Procurement:** Vendor qualification and relationship management .
 - Cost-benefit analysis and bulk purchasing strategies.
- **Logistics & Freight Management:** Multi-modal transport (Air, Sea, Land).
 - Customs clearance and international compliance.
- **Warehousing & Inventory Control:**
 - Real-time stock tracking and JIT (Just-In-Time) delivery.

EQUIPMENTS BROCHURE

❖ **Downhole Motor.**

DAN Oil Services positive displacement motors provide superior performance and longer operating life for today's drilling programs. DAN Oil Services offers a versatile array of Downhole motors available for straight, directional, horizontal, and utility applications. DAN Oil Services motors utilize the industry's best technology in sealed bearing assemblies, adjustable bent housings, and drive lines. DAN Oil Services motors will operate effectively with most drilling fluids in a wide range of fluid weights and viscosities including air, mist and foam.

Some constraints can be imposed by the use of drilling fluids based on synthetics or low aniline mineral oils and when certain additives are being used. This can be discussed further by contacting your local DAN Oil Services representative.

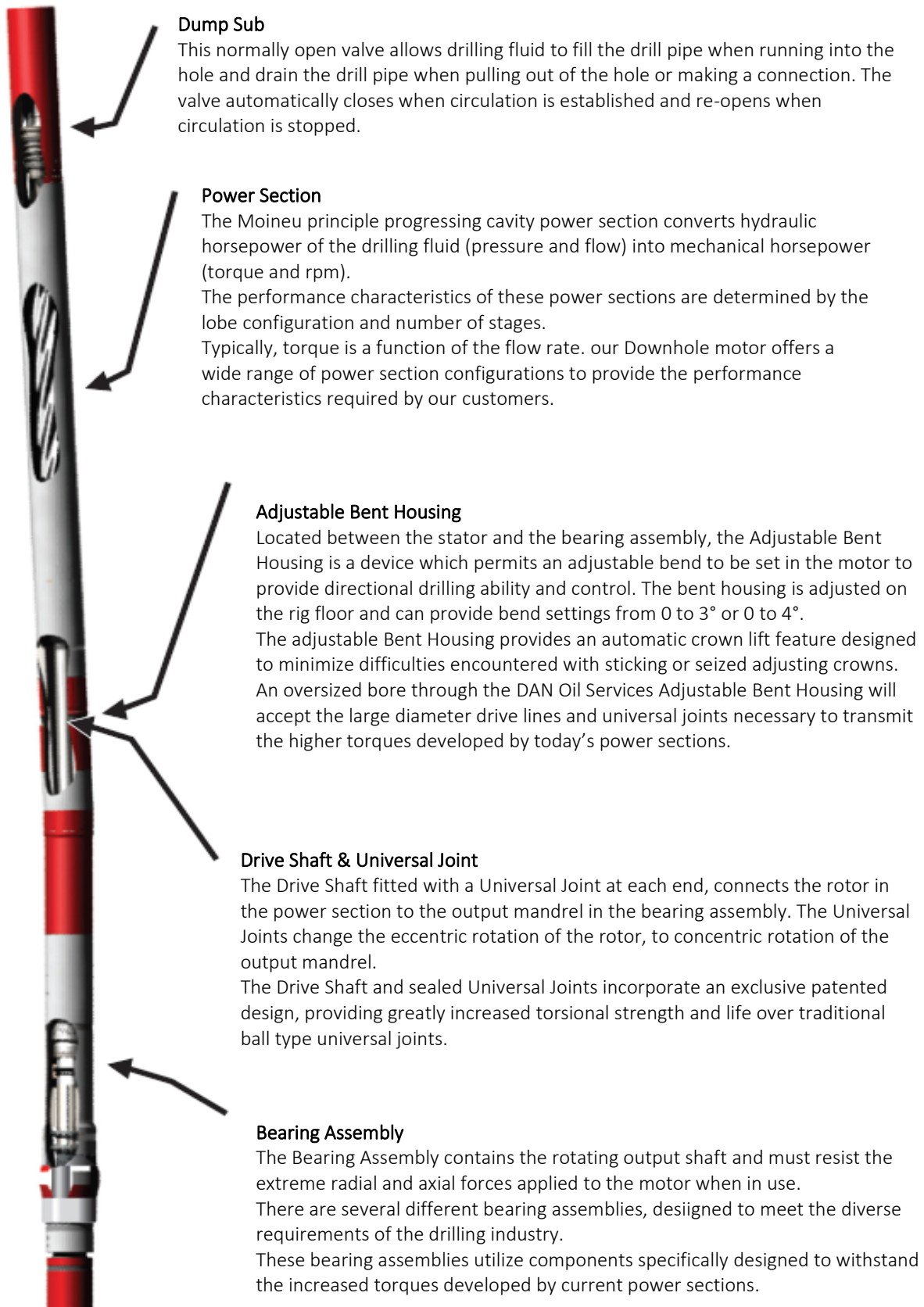

Dump Sub

This normally open valve allows drilling fluid to fill the drill pipe when running into the hole and drain the drill pipe when pulling out of the hole or making a connection. The valve automatically closes when circulation is established and re-opens when circulation is stopped.

Power Section

The Moineu principle progressing cavity power section converts hydraulic horsepower of the drilling fluid (pressure and flow) into mechanical horsepower (torque and rpm).

The performance characteristics of these power sections are determined by the lobe configuration and number of stages.

Typically, torque is a function of the flow rate. our Downhole motor offers a wide range of power section configurations to provide the performance characteristics required by our customers.

Adjustable Bent Housing

Located between the stator and the bearing assembly, the Adjustable Bent Housing is a device which permits an adjustable bend to be set in the motor to provide directional drilling ability and control. The bent housing is adjusted on the rig floor and can provide bend settings from 0 to 3° or 0 to 4°.

The adjustable Bent Housing provides an automatic crown lift feature designed to minimize difficulties encountered with sticking or seized adjusting crowns. An oversized bore through the DAN Oil Services Adjustable Bent Housing will accept the large diameter drive lines and universal joints necessary to transmit the higher torques developed by today's power sections.

Drive Shaft & Universal Joint

The Drive Shaft fitted with a Universal Joint at each end, connects the rotor in the power section to the output mandrel in the bearing assembly. The Universal Joints change the eccentric rotation of the rotor, to concentric rotation of the output mandrel.

The Drive Shaft and sealed Universal Joints incorporate an exclusive patented design, providing greatly increased torsional strength and life over traditional ball type universal joints.

Bearing Assembly

The Bearing Assembly contains the rotating output shaft and must resist the extreme radial and axial forces applied to the motor when in use.

There are several different bearing assemblies, designed to meet the diverse requirements of the drilling industry.

These bearing assemblies utilize components specifically designed to withstand the increased torques developed by current power sections.

6 3/4" (171 mm) MILLENNIUM MUD LUBE DRILLING MOTOR

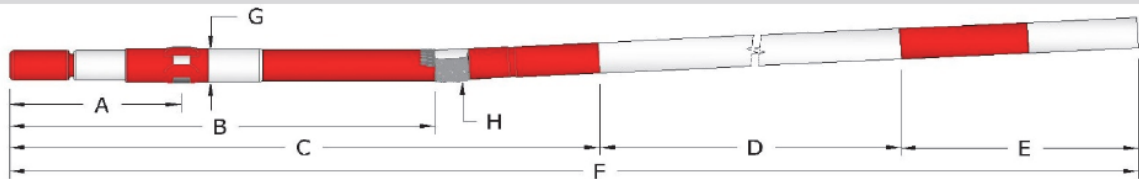

MOTOR SPECIFICATIONS		IMPERIAL	METRIC
Bit Box to Stabilizer	A	28 in	0.71 m
Bit Box to Bend - ABH	B1	65 in	1.65 m
Bit Box to Bend - FBH	B2	53 in	1.35 m
Bottom End Assembly Length	C	93 in	2.36 m
Power Section Length	D	See Power Section Spec Sheet	
Top End Assembly Length	E	61 in	1.55 m
Total Length	F	C+D+E	
Stabilizer Upset Diameter	G	7.75 in	197 mm
Crown Pad Radius	H	3.98 in	101 mm
Recommended Hole Size		8 1/2 - 9 7/8 in	216 - 251 mm
Standard Bit Box Connection		4 1/2 Reg	
Top Connection		4 1/2 IF, 4 1/2 Reg, 4 1/2 XH	
Operating Capacity	Maximum WOB	87,000 lb	39,000 daN
	Maximum Bit Overpull	87,000 lb	39,000 daN
Static Capacity	Maximum WOB to Re-run	360,000 lb	160,000 daN
	Maximum Bit Overpull to Re-run	137,000 lb	61,000 daN
	Absolute Body Overpull	568,000 lb	253,000 daN
Adjustable Make-Up Torque		35,000 ft.lb	47,500 daN
Stabilizer Torque		15,000 ft.lb	20,300 daN
Total Weight		1,300 lb + PS Weight†	590 Kg + PS Weight†

† See power section Spec Sheets for Motor Performance Specifications, Stator Length & Power Section Weight (PS Weight)

ESTIMATED BUILD RATES Deg/100 ft (30 m)									
Bend Setting	Slick Hole Size			One Stabilizer Hole Size			Two Stabilizers Hole Size		
	8.5 in 216 mm	8.75 in 222 mm	9.875 in 251 mm	8.5 in 216 mm	8.75 in 222 mm	9.875 in 251 mm	8.5 in 216 mm	8.75 in 222 mm	9.875 in 251 mm
0.39	0.0	-	-	2.0	2.5	3.5	1.0	1.0	1.0
0.78	3.0	2.0	-	4.5	5.0	6.0	3.5	3.5	3.5
1.15	6.0	5.0	1.5	7.0	7.5	8.0	6.0	6.0	6.0
1.50	8.5	7.5	4.0	9.5	9.5	10.5	8.0	8.0	8.0
1.83	11.0	10.0	6.5	11.5	11.5	12.5	10.0	10.0	10.0
2.12	13.5	12.5	9.0	13.5	13.5	14.5	12.0	12.0	12.0
2.38	15.5	14.5	11.0	15.0	15.0	16.0	14.0	14.0	14.0
2.60	17.0	16.0	12.5	16.5	16.5	17.5	15.0	15.0	15.0
2.77	18.5	17.5	14.0	17.5	17.5	18.5	16.5	16.5	16.5
2.89	19.5	18.5	15.0	18.5	18.5	19.5	17.0	17.0	17.0
3.00	20.0	19.5	15.5	19.0	19.0	20.0	17.5	17.5	17.5

- Note:
- Build Rate tables provide estimates to be used as a guideline. WOB, formation, BHA and bit type will all have an effect on actual build rates produced
 - Build rates are based on Adjustable Bend Housing (ABH)
 - Stabilization points are 1/8" under gauge

8" (203 mm) MILLENNIUM MUD LUBE DRILLING MOTOR

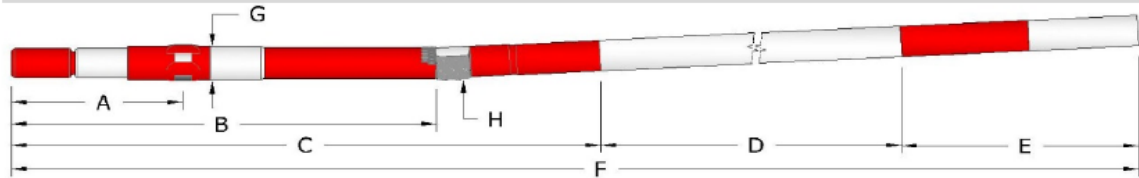

MOTOR SPECIFICATIONS		IMPERIAL	METRIC
Bit Box to Stabilizer	A	34 in	0.86 m
Bit Box to Bend - ABH	B1	78 in	1.98 m
Bit Box to Bend - FBH	B2	65 in	1.65 m
Bottom End Assembly Length	C	110 in	2.79 m
Power Section Length	D	See Power Section Spec Sheet	
Top End Assembly Length	E	62 in	1.57 m
Total Length	F	C+D+E	
Stabilizer Upset Diameter	G	9.20 in	234 mm
Crown Pad Radius	H	4.43 in	112 mm
Recommended Hole Size		9 5/8 - 12 1/4 in	244- 311 mm
Standard Bit Box Connection		6 5/8 Reg	
Top Connection		6 5/8 IF, 6 5/8 Reg	
Operating Capacity	Maximum WOB	112,000 lb	50,000 daN
	Maximum Bit Overpull	112,000 lb	50,000 daN
Static Capacity	Maximum WOB to Re-run	546,000 lb	243,000 daN
	Maximum Bit Overpull to Re-run	216,000 lb	96,000 daN
	Absolute Body Overpull	748,000 lb	348,000 daN
Adjustable Make-Up Torque		45,000 ft.lb	61,000 daN
Stabilizer Torque		40,000 ft.lb	54,200 daN
Total Weight		1,700 lb + PS Weight†	772 Kg + PS Weight†

† See power section Spec Sheets for Motor Performance Specifications, Stator Length & Power Section Weight (PS Weight)

ESTIMATED BUILD RATES Deg/100 ft (30 m)

Bend Setting	Slick Hole Size			One Stabilizer Hole Size			Two Stabilizers Hole Size		
	9.875 in 251 mm	10.625 in 270 mm	12.25 in 311 mm	9.875 in 251 mm	10.625 in 270 mm	12.25 in 311 mm	9.875 in 251 mm	10.625 in 270 mm	12.25 in 311 mm
0.78	2.5	1.0	-	4.5	5.0	6.0	3.5	3.5	3.5
1.15	4.5	3.0	1.0	6.5	7.0	8.0	5.5	5.5	5.5
1.50	7.0	5.5	2.0	8.5	9.0	9.5	7.0	7.0	7.0
1.83	9.0	7.5	4.0	10.5	10.5	11.5	8.5	8.5	8.5
2.12	10.5	9.0	5.5	12.0	12.0	13.0	10.0	10.0	10.0
2.38	12.0	10.5	7.5	13.5	13.5	14.5	11.5	11.5	11.5
2.60	13.5	12.0	8.5	14.5	15.0	15.5	12.5	12.5	12.5
2.77	14.5	13.0	9.5	15.5	15.5	16.5	13.5	13.5	13.5
2.89	15.5	14.0	10.5	16.0	16.5	17.0	14.0	14.0	14.0
3.00	16.0	14.5	11.0	16.5	17.0	18.0	14.5	14.5	14.5

- Note:
- Build Rate tables provide estimates to be used as a guideline. WOB, formation, BHA and bit type will all have an effect on actual build rates produced
 - Build rates are based on Adjustable Bend Housing (ABH)
 - Stabilization points are 1/8" under gauge

9 5/8" (244 mm) MILLENNIUM MUD LUBE DRILLING MOTOR

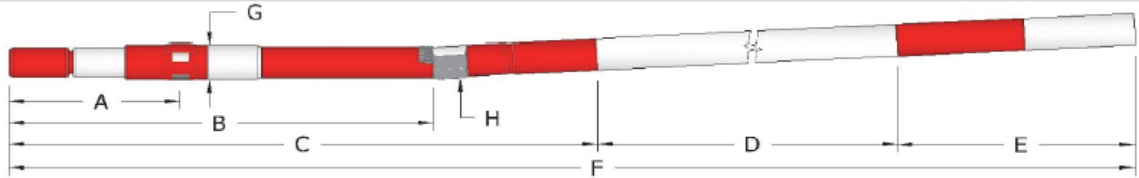

MOTOR SPECIFICATIONS		IMPERIAL	METRIC
Bit Box to Stabilizer	A	46 in	1.17 m
Bit Box to Bend - ABH	B1	96 in	2.44 m
Bit Box to Bend - FBH	B2	98 in	2.49 m
Bottom End Assembly Length	C	130 in	3.30 m
Power Section Length	D	See Power Section Spec Sheet	
Top End Assembly Length	E	60 in	1.52 m
Total Length	F	C+D+E	
Stabilizer Upset Diameter	G	10.75 in	273 mm
Crown Pad Radius	H	5.26 in	134 mm
Recommended Hole Size		12 ¼ - 17 ½ in	311 – 445 mm
Standard Bit Box Connection		6 5/8 Reg	
Top Connection		6 5/8 Reg	
Operating Capacity	Maximum WOB	132,000 lb	59,000 daN
	Maximum Bit Overpull	132,000 lb	59,000 daN
Static Capacity	Maximum WOB to Re-run	772,000 lb	343,000 daN
	Maximum Bit Overpull to Re-run	223,000 lb	99,000 daN
	Absolute Bit Overpull	1,177,000 lb	524,000 daN
Adjustable Make-Up Torque		60,000 ft.lb	81,400 Nm
Stabilizer Torque		40,000 ft.lb	54,200 Nm
Total Weight		3,450 lb + PS Weight [†]	1566 Kg + PS Weight [†]

[†] See power section Spec Sheets for Motor Performance Specifications, Stator Length & Power Section Weight (PS Weight)

ESTIMATED BUILD RATES Deg/100 ft (30 m)									
Bend Setting	Slick Hole Size			One Stabilizer Hole Size			Two Stabilizers Hole Size		
	12.25 in 311 mm	14.75 in 375 mm	17.5 in 445 mm	12.25 in 311 mm	14.75 in 375 mm	17.5 in 445 mm	12.25 in 311 mm	14.75 in 375 mm	17.5 in 445 mm
Deg.									
0.78	2.0	-	-	4.5	5.5	6.5	3.5	3.5	3.5
1.15	4.5	1.0	-	6.0	7.5	8.5	5.0	5.0	5.0
1.50	6.5	2.5	1.0	8.0	9.0	10.0	7.0	7.0	7.0
1.83	8.0	4.0	1.5	9.5	10.5	11.5	8.5	8.5	8.5
2.12	9.5	6.0	2.5	11.0	12.0	13.0	10.0	10.0	10.0
2.38	11.0	7.0	3.0	12.0	13.0	14.5	11.0	11.0	11.0
2.60	12.5	8.5	4.0	13.0	14.5	15.5	12.0	12.0	12.0
2.77	13.5	9.5	5.0	14.0	15.0	16.5	13.0	13.0	13.0
2.89	14.0	10.0	6.0	14.5	15.5	17.0	13.5	13.5	13.5
3.00	14.5	10.5	6.5	15.0	16.0	17.5	14.0	14.0	14.0

- Note:
- Build Rate tables provide estimates to be used as a guideline. WOB, formation, BHA and bit type will all have an effect on actual build rates produced
 - Build rates are based on Adjustable Bend Housing (ABH)
 - Stabilization points are 1/8" under gauge

❖ Deviation Control Reamer.

The Downhole Deviation Control Reamer (DCR Sub) acts as a near bit reamer/stabilizer. The three point sealed bearing cutters maintain hole gauge and also function as a low torque stabilizer to control hole deviation. The extremely short length of this sub is possible due to the unique patented cutter retention method.

Features:

- Sealed and lubricated reamer cutters with internal bushings provide the greatest durability in a near bit environment.
- Cutter pins are produced from hardened steel for long life.
- Cutter types; domed button or straight ridge.
- Replaceable thrust washers are installed at each end of the cutters.
- Cutter blocks are precision machined to ensure correct gauge. They are manufactured from alloy steel and finished hardened for a superior combination of strength and wear resistance.
- No bolts or screws are used to retain the reamer blocks

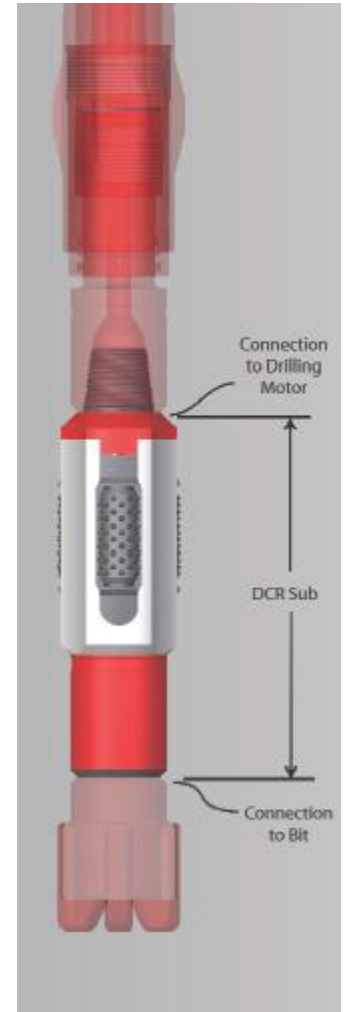

❖ Wireless Drift Indicator.

TELEDRIFT

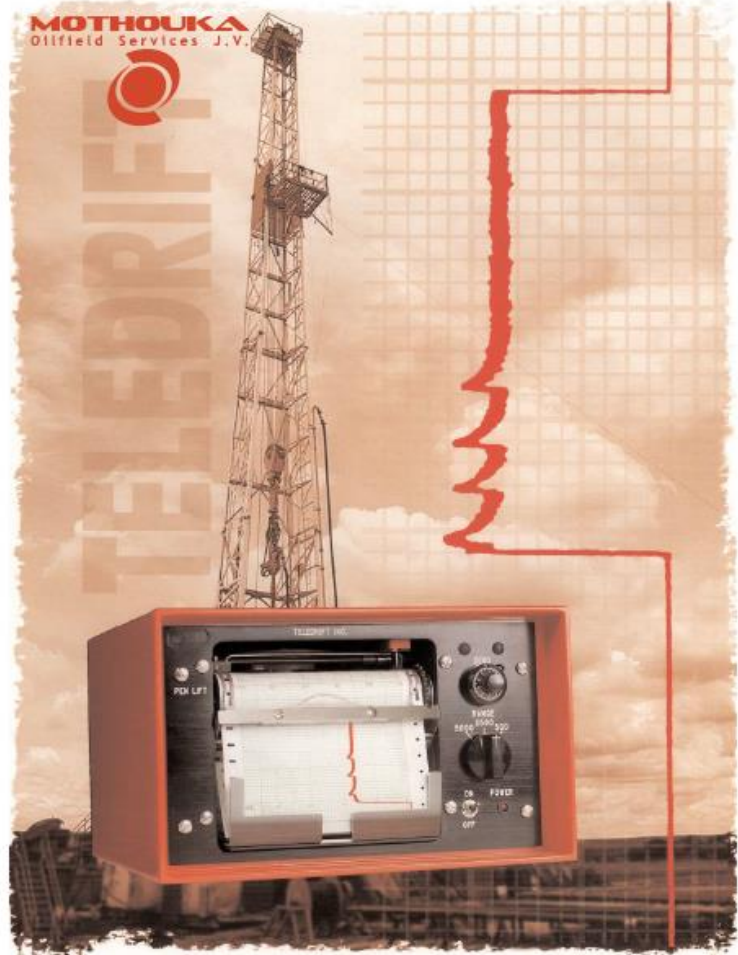

THE 'TELE' CONCEPT

Teledrift speeds drilling by providing almost instantaneous surface recordings of hole deviations without making round trips or running wire lines.

The unit, which is operated by rig personnel, is a rugged, stainless steel, mechanical device which

Teledrift wireless drift indicator measures deviation angles to 17 degrees.

measures well-bore angle in one-half degree increments and transmits the information to an electronic recorder via mud pulse telemetry. The first patents on mud pulse telemetry were issued for the Teledrift instrument, thus making it the "Original MWD".

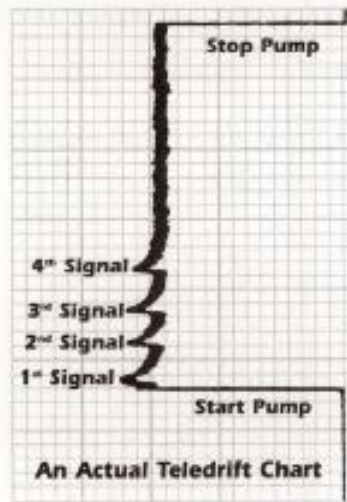

The Teledrift gives readings in one-half degree ($1/2^\circ$) increments or it can also be configured to measure in one-degree (1°) increments. The latter has a tool range of seven degrees (7°) without re-setting the instrument. The "wide angle" Teledrift instrument measures deviation in one-degree (1°) increments, up to seventeen degrees (17°).

HOW TELEDRIFT WORKS

The Teledrift tool consists of a pendulum at the bottom that moves along a series of graduated stop shoulders, and a signaling plunger at the top that traverses a series of seven annular restrictions to produce pressure pulses in the mud stream. Plunger travel is controlled by a patented coding system so that deviation of the hole from the vertical increases the number of pulses generated. A maximum of seven signals can be generated, each representing an increment of hole angle of one-half or one degree (see chart).

EASY TO USE

Teledrift readings can be made any time during drilling. When drilling is stopped during both the measuring and the signaling periods, maximum downtime is generally 5 to 6 minutes. Downtime may be reduced to only 3 to 4 minutes by resuming drilling during the signaling period. For maximum clarity of signals, take readings between connections, when the mud is very fluid, with no air in the pipe. Downtime may also be minimized by measuring the drift angle just before making a connection and receiving the signals after completing the connection, when the pump is started.

The most reliable operations is obtained by making the angle measurement and recording signals in one unbroken sequence between connections. This produces maximum signal clarity with minimum possibility of errors.



PROCEDURE FOR TAKING TELEDRIFT READINGS

1. Stop rotating.
2. Pull off bottom 10 feet, according to usual practice. Set Brake.
3. Shut down pumps AFTER rotation has been stopped.
4. Measurement of drift angle requires 3 minutes after mud flow has stopped. Do NOT move pipe during this period.
5. Start pumps and bring up to speed smoothly. Maintain mud flow at constant rate for 2 minutes after last signal is received.
6. Use chart inside folder to obtain deviation angle from recorded signals.
7. To change "Angle Range" setting of Teledrift instrument refer to Operator Manual.
8. Record date, depth, and angle of deviation on strip chart.

TELEDRIFT ANGLE RANGE SETTINGS
HALF DEGREE CHART (1/2°)

ANGLE RANGE	NUMBER OF SIGNALS						
	1	2	3	4	5	6	7
1/2-3	1/2	1	1 1/2	2	2 1/2	3	3+
1 -3 1/2	1	1 1/2	2	2 1/2	3	3 1/2	3 1/2+
1 1/2-4	1 1/2	2	2 1/2	3	3 1/2	4	4+
2 -4 1/2	2	2 1/2	3	3 1/2	4	4 1/2	4 1/2+
2 1/2-5	2 1/2	3	3 1/2	4	4 1/2	5	5+
3 -5 1/2	3	3 1/2	4	4 1/2	5	5 1/2	5 1/2+
3 1/2-6	3 1/2	4	4 1/2	5	5 1/2	6	6+
4 -6 1/2	4	4 1/2	5	5 1/2	6	6 1/2	6 1/2+
4 1/2-7	4 1/2	5	5 1/2	6	6 1/2	7	7+
5 -7 1/2	5	5 1/2	6	6 1/2	7	7 1/2	7 1/2+
5 1/2-8	5 1/2	6	6 1/2	7	7 1/2	8	8+
6 -8 1/2	6	6 1/2	7	7 1/2	8	8 1/2	8 1/2+
6 1/2-9	6 1/2	7	7 1/2	8	8 1/2	9	9+
7 -9 1/2	7	7 1/2	8	8 1/2	9	9 1/2	9 1/2+
7 1/2-10	7 1/2	8	8 1/2	9	9 1/2	10	10+

DEVIATION ANGLE IN DEGREES

Reading The Chart: Each Teledrift signal indicates one-half degree of angle. The value of each signal depends on the angle range setting of the downhole instrument. The table above shows the maximum angle of each of the seven possible signals at each of 15 range settings.

WIDE ANGLE CHART

ANGLE RANGE	NUMBER OF SIGNALS						
	1	2	3	4	5	6	7
1-7	1	2	3	4	5	6	7
2-8	2	3	4	5	6	7	8
3-9	3	4	5	6	7	8	9
4-10	4	5	6	7	8	9	10
5-11	5	6	7	8	9	10	11
6-12	6	7	8	9	10	11	12
7-13	7	8	9	10	11	12	13
8-14	8	9	10	11	12	13	14
9-15	9	10	11	12	13	14	15
10-16	10	11	12	13	14	15	16
11-17	11	12	13	14	15	16	17

DEVIATION ANGLE IN DEGREES

ONE DEGREE CHART (1°)

ANGLE RANGE	NUMBER OF SIGNALS						
	1	2	3	4	5	6	7
1-7	1	2	3	4	5	6	7+
2-8	2	3	4	5	6	7	8+
3-8 1/2	3	4	5	6	7	8	8 1/2+
4-9	4	5	6	7	8	8 1/2	9+
5-9 1/2	5	6	7	8	8 1/2	9	9 1/2+

DEVIATION ANGLE IN DEGREES



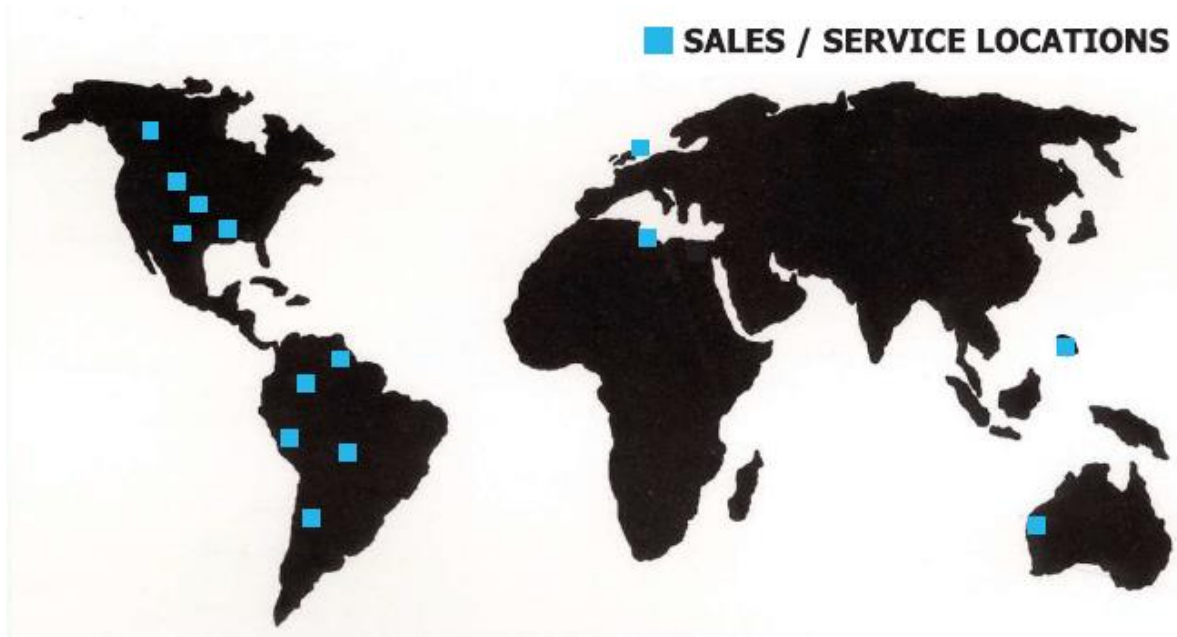

ADVANTAGES TO THE TELEDRIFT WIRELESS DRIFT INDICATOR

- ① Less Chance Of Getting Stuck
- ① Fast Surveys At Any Depth
- ① Increased Penetration Rates
- ① More Frequent Surveys
- ① Saves Costly Down Time
- ① Accurate To One-Half Degree
- ① No Hydraulic Hook Ups
- ① Permanent Record Of Surveys
- ① Less Cost Than Full MWD



❖ Measurement While Drilling Tool (MWD).



SureShot

*Advanced Systems for
Drilling Performance*



*Fixed-mount
Pulser*



Rig Floor Display



SureShot "Lite" Version

“Open Platform” MWD System

Sureshot™, the “ open-Platform” MWD system, provides Cost effective and flexible mud-pulse Directional and Directional-Gamma services. The system promotes drilling efficiency through the rapid, reliable provision of accurate real-time survey and steering data with optional Gamma logging. This highly cost effective MWD system will provide azimuth and inclination data at the required accuracy from “straight hole” to “horizontal” drilling operations. Rapid and accurate toolface transmission enables the most complex well path to be drilled with confidence. High-quality Gamma logging can be added easily.

Sureshot™ includes a rugged, cost effective directional sensor package; a reliable, field proven, battery or turbine alternator powered pulser*; and small, robust surface decoder which interface with a computer running Sureshot Control center software.

Each package is protected by state of the art vibration isolation system and is mounted in beryllium copper high strength steel pressure barrels.

Our specified electronics provide solid functionality while meeting all required accuracy specifications.

Advanced Systems for Drilling Performance



*Retrievable
Pulser*



*Rugged Rack Mount
MWD Surface Gear*

- ❖ The highly reliable pulser assembly is unique in that it can be easily converted from fixed-mount to retrievable, providing critical flexibility. Fixed Mount reliability or retrievable LIH Security.
- ❖ Additional sensors including Gamma, Vibration monitoring, pressure while drilling and resistivity can be quickly incorporated into the “LWD-Ready” system architecture using our sensors or yours.
- ❖ Our System uses industry in an “open platform” architecture based on RS485. Clients are able and encouraged to add internally developed sensors.
- ❖ The surface system presents the data in a simple, user friendly control and display module. The data is transferred to a central control PC from which it can be directed back to dedicated “wireless” Rig floor Display and/or the rig monitoring System.
- ❖ Multiple encoding schemes are embedded in the system to enable rapid customization of the data stream. Maximum speed or Maximum data integrity.
- ❖ The unique APS power Management Module enables the system to be powered through dual battery packs or a combination of battery power and Turbine Alternator. Nearly all module is compatible with existing our system

Technical Data Sheet

“Open Platform” MWD System

Operating Specification	
Inclinaton Range	0° - 180°
Inclinaton Accuracy	0.1°
Azimuth Range	0° - 360°
Azimuth Accuracy	0.1° (In > 10°, Dip < 70°)
Tool Face (Gravity)	0.1°
Tool Face Magnetic)	2.25° (In > 10°, Dip < 70°)
Sensors	
Tri-Axial Magnetometers	Quartz Accelerometers
Productt Specifications	
Singal Transmission	Positive mud pulse
Pulse Height	Adjustable
Retrievable/ Resealable	Available
Fixed- Mount	Available
Activation	Electromechanical
Operating Vo;tage	28 - 40 VDC
Pulser Sub O.D.	9.5, 8, 6.25, to 6.75, 4.75, 3.5, & 3.125 in.** 241, 203, 159 to 171, 121, 89 & 79mm**
Flow Rate	9.5in. or Larger 650 to 1200 gpm 241mm or Larger 41 to 76 L/sec
	8in. 300 to 1100 gpm 203mm 19 to 69 L/sec
	6.25 to 6.75in. 150 to 750 gpm 159 to 171mm 9 to 47 L/sec
	4.75in. 150 to 350 gpm 121mm 9 to 22 L/sec
	3.125 & 3.5in. 70to 250 gpm 79 & 89mm 4 to 16 L/sec
Sand Content	< 1% by volume recommended , 3 % by volume max
LCM Tolerance	50lb/bbl medum nut plug 143 kg/m3 medum nut plug
Shock	500 g, 1 ms, 5,000 shock per axis
Vibration	25g RMS, 20 - 500 Hz bandwidth
operating Temperature	-13° to 302° F, 347° F option -25° to 150° C, 175° C option
Maximum Presure	20,000 psi 137.9 Mpa
Differential Presure	No requirment
Doglog Capability	API connection limited
Surface System	
Electrical Requirments	100 -240 VAC, 50-60 Hz, 13 W
operating Temperature	14° to 185° F -10° to 85° C
Storage Temperature	33° to 185° F 1° to 85° C
Version A (rack mount Directional)	Case - 19in. EIA Standerd Case - 483mm. EIA Standerd
	17in. (h) x 27in. (w) x 34.25in. (d) 482mm (h) x 686mm. (w) x 870mm (d) weight -125 lbs weight -56.7 kg
Version A (rack mount)	Case - 19in. EIA Standerd Case - 483mm. EIA Standerd
	17in. (h) x 27in. (w) x 34.25in. (d) 482mm (h) x 686mm. (w) x 870mm (d) weight -100 lbs weight -45.4 kg
Version B (small footprint)	5.5in. (h) x 22in. (w) x 20in. (d) 140mm (h) x 559mm. (w) x 508mm (d) weight -22 lbs plus labtop weight - 10 kg plus labtop
	5.5in. (h) x 22in. (w) x 20in. (d) 140mm (h) x 559mm. (w) x 508mm (d) weight -22 lbs plus labtop weight - 10 kg plus labtop
Version B (small footprint) Plotter	7.25in. (h) x 22in. (w) x 20in. (d) 184mm (h) x 559mm. (w) x 508mm (d) weight -37 lbs weight - 16.8 kg
	7.25in. (h) x 22in. (w) x 20in. (d) 184mm (h) x 559mm. (w) x 508mm (d) weight -37 lbs weight - 16.8 kg
Rig Floor Display	Certified Zone 1 Division2; wirless or 15in wired/wireless connections
Pressure Transducer	4 - 20 mA current loop, Certified Zone 1 Division 2
Hookload	4 - 20 mA current loop, Certified Zone 1 Division 2
Depth Encoder	Standerd NAMUR type, Certified Zone 1 Division 2

❖ Shock Tools and Drilling Jar.

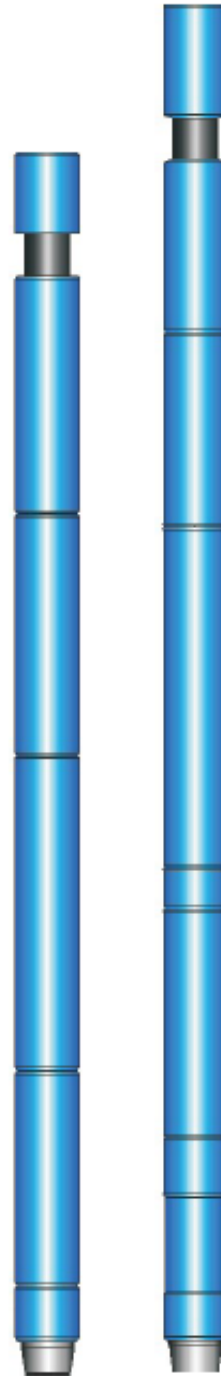
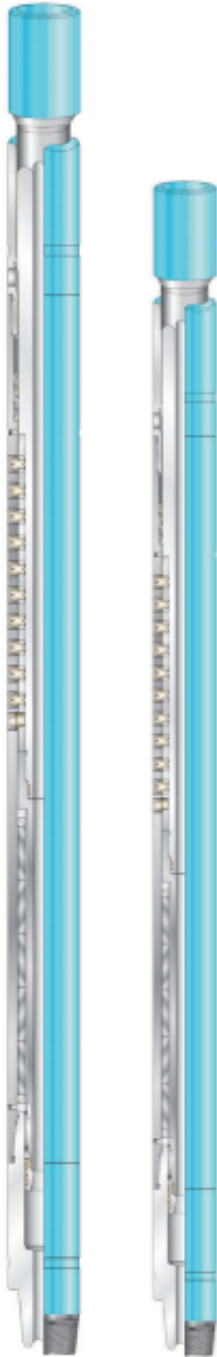

Shock tool

The Shock Tool effectively reduces impact loading on the bit to extend bit life and reduce bit trips. By isolating axial bit vibrations from the drill string, the shock tool will reduce lateral and torsional drill string vibrations, and related fatigue damage or failure of the rotary connections. The shock tool allows optimum bit speed to be used under rough drilling conditions, increasing the rate of penetration.

Design Features

- Does not use temperature-sensitive elastomers for shock absorption, therefore is suitable for use in temperatures to 250°F (120°C), with optional seals available for temperatures up to 320°F (160°C).
- Reliable Belleville disc springs provide optimum load/deflection characteristics to maintain consistent contact between bit and formation, effectively reducing impact loading to extend bit life.
- Isolates bit induced vibrations from the drill string.
- Fully oil-sealed and lubricated for extended service life.
- Pressure balanced to eliminate the effect of downhole hydrostatic pressure.
- Low friction torsional drive permits free vertical movement.
- Well-stabilized, with internal three-point lateral support to minimize deflection.
- Reduces wear and tear on rig and equipment, and fatigue failures on drill collars and drill pipe.
- Automatically compensates for pump open force

Shock Tool Operation

- For maximum effectiveness, the shock tool should be positioned immediately above the bit.
- With a packed bottom hole assembly, the shock tool may be located a minimum of two drill collar lengths above the top stabilizer, however bit protection will be reduced due to the greater un-sprung mass below the tool.
- Automatic compensation of pump open effect makes the shock tool effective with any combination of bit weight or circulating pressure.

Drilling Jar

The Jar operates with a simple up and down motion and is insensitive to right- or left-hand torque. It is most commonly run as a hydraulic/mechanical, but can be run as a mechanical jar, by omitting the valve, or as a hydraulic jar by omitting the latch. When configured as a hydraulic/mechanical jar or straight mechanical jar, it is run in the latched position.

This eliminates unexpected jarring and prolongs seal life.

Design Features

- Jar will NOT accidentally fire when making connections, drilling, tripping, or tagging bottom.
- Safety clamps or special handling procedures are NOT required.
- Jar placement is more flexible than with hydraulic jars. These jars can be run in tension or compression provided the preset latch settings are not exceeded.
- Lower connection time than hydraulic jars when run in compression. The mechanical latch eliminates the need to wait for the hydraulic delay when tagging bottom or picking up off bottom.
- Mechanical latch is NOT affected by right or left hand torque
- Mechanical latch release settings are shop adjustable.
- Up jarring impact force can be altered after the latch setting has been exceeded by changing the overpull during the hydraulic delay sequence.
- Standard seals are effective up to 250°F (120°C)
- Optional high temperature seals are rated for up to 400°F (204°C)
- Carbide coating and the downhole's specialized polishing process on all mandrel sealing surfaces greatly enhances seal and tool life in a broad variety of drilling environments.

Jar Operation

- To jar upwards the tension force at the jar must exceed the up latch setting. When the latch setting is exceeded the tension force can be increased or decreased during the hydraulic delay period, which is typically between 30 and 90 seconds. The jar then enters free stroke and the hammer surface of the jar accelerates until it contacts the anvil surface of the jar thus exerting an upward impact force at the stuck point. The jarring cycle can be repeated by lowering the drill string to re-engage the mechanical latch.

- To jar downwards the compression force at the jar must exceed the down latch setting. There is no hydraulic delay when jarring down. After exceeding the down latch setting the jar closes immediately exerting a downward impact force at the stuck point. The jarring cycle can be repeated by raising the drill string to re-engage the mechanical latch.
- Circulating while jarring will cause a pump open force. This force can be calculated by multiplying the pressure drop across the bit by the pump open area shown on the jar specific cation table. This force will reduce the overpull required to overcome the up-latch setting, and increase the compressive force required to overcome the down latch setting.
- The down latch releases at approximately 45% of the up-latch setting.

❖ CT Equipment



Safety & Health

The following are general safety precautions. Personnel must understand and apply these precautions during all phases of operation and maintenance of this equipment.

Specific precautions will be included in the text for certain potentially hazardous operations in the form of **WARNING** or **CAUTION statements**. Some of the warnings appear in the text of this publication but are presented here for emphasis.

- **Qualified Personnel**
Only qualified personnel should be authorized to operate and perform maintenance on this equipment.
- **Protective Equipment**
Personnel operating and performing maintenance on this equipment should wear suitable protective clothing and equipment.
- **Unauthorized Personnel**
Keep unauthorized personnel away from the unit when operating, servicing, or performing maintenance.
- **Safety Practices**

Overall good safety practices should be adhered to at all times when setting up, operating, shutting down and maintaining this equipment. It is the equipment owner's/operator's responsibility to ensure that good safety practices, personnel training programs, and safety practices are maintained.

- **High Pressures**

Ensure pressure in piping connected to the unit has been bled to zero (0) before attempting to disconnect any equipment.

- **Unauthorized Maintenance**

Do not attempt unauthorized disassembly or maintenance of components. Some components, such as accumulators, store fluids under pressure. Contact your NOV Hydra Rig representative for further information.

- **Lifting**

Equipment used in lifting and moving the unit must be of sufficient rating to handle the weight involved.

Control Cabin



Power Pack



C T Pressure Control Equipment

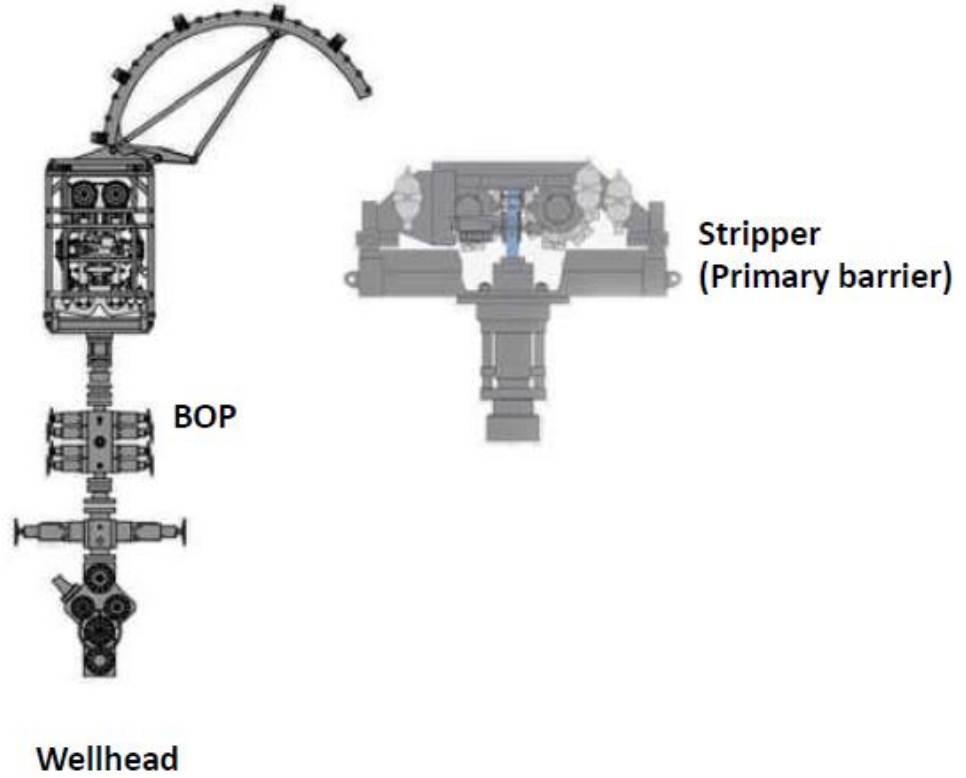

Stripper

Description

The stripper is the primary well control barrier on CT operations. It is sometimes referred to as the stuffing box.

The stripper provides the annular seal, which is the seal between the CT string and the wellbore. It contains the WHP by compressing an elastomer seal, or stripper element, around the CT string. This seal allows full pressure control while the CT string is moving into or out of the well. It is the stripper's function that allows CT operations to be carried out in live oil and gas wells.

The stripper is normally pinned directly to the bottom of the CT injector head.

The stripper is run on a hydraulic system, which is controlled from inside the control cabin of the CT unit (CTU).



Stripper 4.06" Dual SD

Side door stripper

Side door strippers are preferred over conventional strippers because of design features that give improved safety and ease of use. They are the most common model of CT stripper. The side door stripper was introduced to enable easier and safer replacement of stripper inserts while the equipment is rigged up.

As the name suggests, this model of stripper has a side door that allows direct access to the internal components of the stripper. This door means that the stripper can be serviced easily during a job, even with the CT string in the well. The side door design permits replacement of the element, energizer, and non-extrusion rings by hydraulically retracting the pack-off piston and exposing an open window on the side of the stripper. This feature is particularly advantageous when changing the stripper element with tubing in the well. This model of stripper has a longer section of brass bushings than the conventional stripper. This section gives improved centralization of the CT string to reduce stripper insert wear.

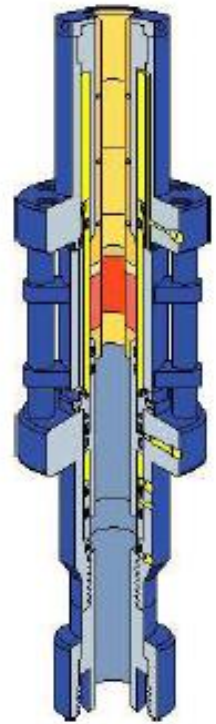

Stripper Component

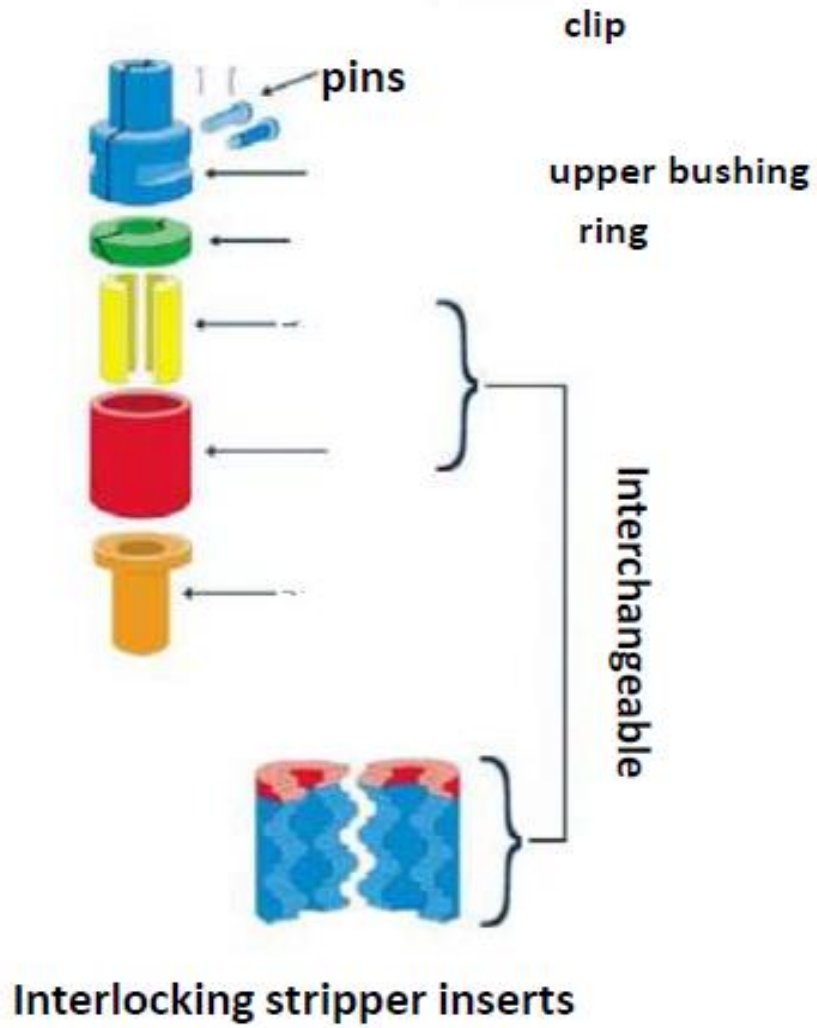

Injector Head

HYDRA RIG HR5100 INJECTOR

Specifications

Weights Injector..... 16,000 lb (7,258 kg).
 With Gooseneck and Stripper Mount18,000 lb (8,165 kg).



- **Injector System Lubricants**

- **HYDRAULIC MOTOR**

DRIVECASE	MOTOR	CHAIN	BEARINGS	GOOSENECK	DRIVE SHAFTS	CHAIN DIP
STD- AMB TEMPS 15° & ABOVE: 85W-140 ARCTIC - AMB TEMPS 80° & BELOW: 75W-90	AW-46	HD30 Oil	2EP Grease	2EP Grease	NLGI O Grease	HD30 Oil

Type..... Variable Displacement, Bent Axis, Piston.
 Maximum Motor Displacement (Low speed, full displacement).... Low "Gear" – 15.86 in³.

- **HYDRAULIC MOTOR SPEED SHIFT PRESSURE**

Starts to de-stroke from full displacement..... 75 psig
 Minimum displacement 120 gpm supply = 9.52 in³ or 156 cc
 100 gpm supply = 7.92 in³ or 130 cc

- **BRAKE**

Brake..... Fail safe, Modular
 Brake Actuation..... Automatic, loss of pressure
 Brake Release Pressure... Begins at 160 psi, full release at 215 psi, 3000 psi Maximum
 Static Brake Torque..... 20,000 in. /lb. (NEW)
 200,000 lb Equivalent Tubing Force

- **GEAR DRIVE**
 Gear ratio..... 74:1
 Type..... Custom Design Spur
 Oil Capacity (Refer to “Oil Level Instructions”) .. 21 gal estimated (Actual capacity varies fill to fill. Level label is located on the gear drive.)
- **MINIMUM CHAIN (TUBING) SPEED**
 Low Gear Only..... Less than 1 fpm
- **MAXIMUM CHAIN (TUBING) SPEED**
 Low Gear 84 fpm
 High Gear..... 140 fpm
- **TUBING PULL TO DRIVE PRESSURE RATIO**
 Low Gear..... Approximately 21.7 lb/psi
 High Gear (120 gpm minimum displacement)..... Approximately 13.0 lb/psi
- **RATED PULL**
 Low Gear (4,600 psi drive pressure)..... 100,000 lb.
 High Gear (5,000 psi drive pressure) (120 gpm minimum displacement)..... 65,000 lb.
- **RATED SNUBBING FORCE**
 Low Gear..... 50,000 lb.
- **Injector Traction System**
 Skate..... Hardened, reversible
 Length of Grip Zone..... 41.5 in. (105 cm)
 Quantity of Grippers in Grip Zone..... 9 Pairs
 Quantity of Traction Cylinders.....8
 Maximum Traction Pressure..... 3,000 psi
 Accumulator..... 3 each, 0.25 gallon.
- **Injector Chain Tension**
 Cylinders..... Four 3.5 in. Bore
 Minimum Recommended Operating Pressure..... 800 psi
 Maximum Pressure..... 3,000 psi

- **Load Cell Options**

- **Electronic Plate Type**

Dual Acting (Tension/Compression) Manufacturer..... MD/Totco or Sensotech.
Type..... Strain Gauge
Outputs..... 4-20 ma
Tubing Load Range..... -100,000 to +100,000 lb.
Excitation Voltage..... 8.1 to 28 VDC
Operational Temperature Range..... -65°F to +250°F
Nominal Output (Including Tare):
Full Pull (100,000 lbs)..... 17.60 mA
Zero Pull (12,000 lbs tare)..... 12.60 mA
Full Snub (-50,000 lbs)..... 10.10 mA

- **Hydraulic Load Cell (2- EACH)**

Stacked (Tension/Compression)
Manufacturer..... MD/Totco
Type..... Diaphragm
Outputs..... 0-1250 psi
Tubing Load Range..... -100,000 to +100,000 lb
Operational Temperature Range..... -65°F to +250°F
Nominal Output (Including Tare):
Full Pull (100,000 lbs)..... 1120 psi
Zero Pull (12,000 lbs tare)..... 120 psi
Full Snub (-50,000 lbs) 380 psi

Gooseneck

Setting Gooseneck Alignment

- Apply 800 psi to the chain tension circuit. Ensure that traction pressure is shut off to the Traction circuits.
- Rotate chains ten revolutions and inspect chains visually to ensure
- Smooth rotation with the proper tension.
- Apply 100 psi to the traction circuit, insert the tubing into the chains, and then drive the injector in-hole to pull the tubing through the injector and stripper. A stabbing device is very helpful for this purpose.
- Once the tubing is completely through the injector and stripper, increase traction pressure to 400 psi.
- Look down into the injector chains from the top of the injector, observing the area where the tubing first contacts the chains.
- Loosen the jam nut and adjust the gooseneck by turning the screw at the rear of the frame until the tubing is 1/8" to 1/4" off the center of the area near the chains, toward the reel.

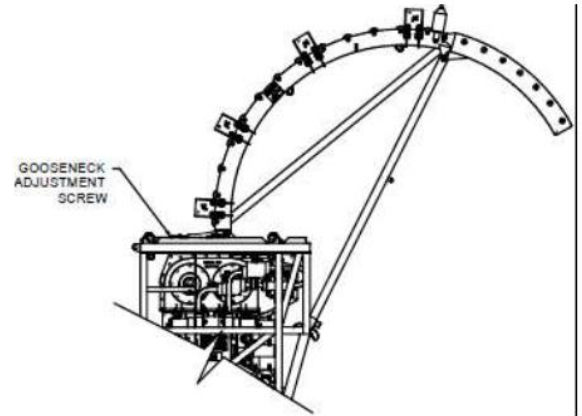

100" Gooseneck and Rollers

100" Gooseneck

The gooseneck supports and directs the tubing as it enters and exits the injector. The gooseneck is flared on the end to allow for the tubing reel fleet angle. The flared end can be raised and pinned in position for operation. Rollers are available for all tubing sizes up to 3.50 in. OD tubing. The gooseneck is pinned to an adjustable mount. This mount must be adjusted according to the curvature of the tubing so that the tubing enters at the center of the chains.

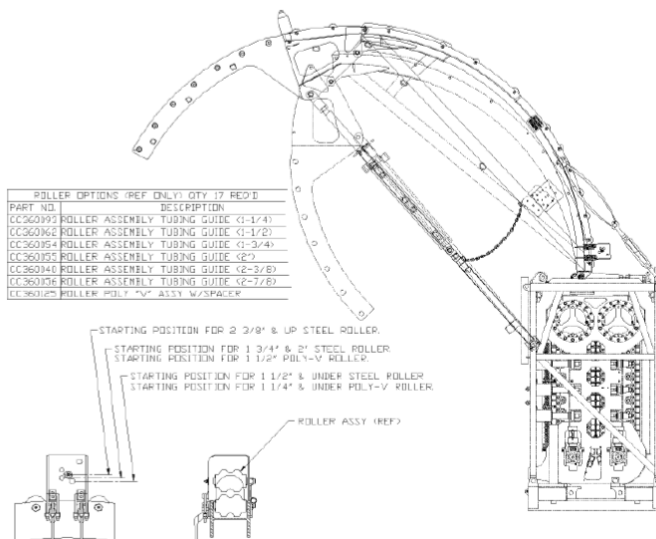

- TUBING GUIDE..... 120" (100" option)
- TUBING GUIDE ROLLER.....2.38

• TUBING GUIDE (GOOSENECK) ADJUSTMENT

Injectors are designed to operate correctly when coiled tubing enters the injector through the center of the two chains. All Hydra Rig injectors are fitted with gooseneck mounts that are adjustable to allow front to back adjustment to achieve this. It is a common misconception that the gooseneck needs to be aligned one time and that adjustment will be good for the life of the injector. This is not the case. The gooseneck alignment should be checked at the beginning of every job. A correctly aligned gooseneck will allow the tubing to enter the injector chains evenly, not hitting the front or the back chain before the other. Proper gooseneck alignment can only be achieved using the tubing you intend to run and any changes in tubing, such as O.D. change or wall thickness change, will require realignment.

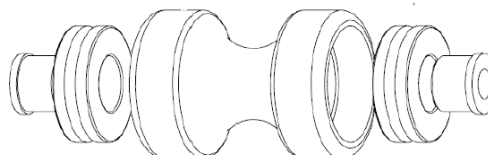
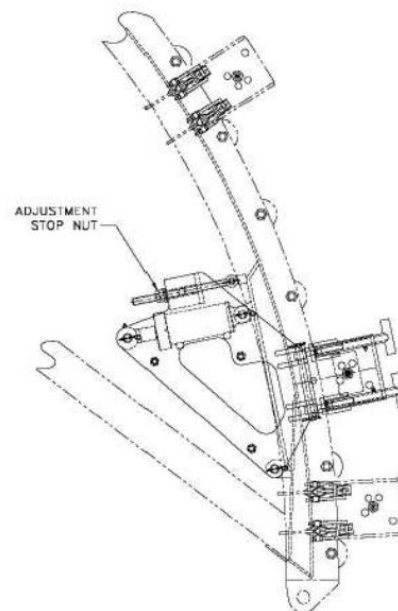

CT Reel



HYDRA RIG 4125 CT REEL

Specifications

Weights

Reel without tubing.....	16,500 lb (7,484 kg)
Reel with 17,000 feet of 2.38" (0.118" wall) tubing.....	69,700 lb (31,616 kg)
Maximum Gross lift weight (2-point).....	115,000 lb (52,164 kg)

Dimensions

Core Diameter.....	96 in. (244 cm)
Width Between Flanges.....	88 in. (224 cm)
Flange Diameter.....	168 in. (427 cm)

- **Counter..... RC-203 2.38 F**
- **Swivel Size..... 2" 10K"**
- **Reel Speed @ 28GPM/2500 PSIG**

Speed, Max first layer (bare reel).....	326 ft/min (99 m/min)
(Speed increases with each layer of tubing.)	
Pulling force, max first layer (bare reel).....	3,250 lb (474 kg)
Pulling force, max last layer (full reel).....	2,000 lb (907 kg)
Maximum tubing size.....	2.38"

- **Hydraulic Maximum Flows and Pressures**

Levelwind override and levelwind lift circuit.....	13 GPM/0 – 2500 PSIG
Reel motor drive circuit.....	33 GPM/0 – 2500 PSIG
Reel motor case drain, protected by a pop-off relief valve set at:.....	10 PSIG
Reel motor brake, protected by a pop-off relief valve set at:.....	500 PSIG

Reel Controls and Indicators

The location for the controls and indicators are in the cabin. The labels and function of the controls are listed below.

CONSOLE INDICATORS

- Circulating Pressure - This indicates circulating pressure measured inside the tubing at the external plumbing just before the swivel.
- Wellhead Pressure - This indicator displays the pressure at the wellhead.
- Weight Indicator - A gauge indicating the tubing weight.

TUBING REEL CONTROLS AND INDICATORS

- Reel Pressure Adjust - A remote relief valve is used to adjust the hydraulic pressure to the tubing reel drive motor.
This valve allows the operator to remotely adjust the tension the reel applies to the tubing.
- Reel Pressure - A gauge that indicates the hydraulic pressure to the reel drive motor.
- Reel Brake - A 3-way on/off valve used in directing hydraulic fluid to the reel brake to release the brake.
- Reel Brake Pressure - A gauge that indicates pressure in the reel brake.
- Levelwind Override - A 4-way valve that will override the mechanical levelwind.
- Levelwind Arm - A 4-way valve that raises and lowers the levelwind arm.
- Reel Control - A 4-way valve that is used to select the direction of the tubing reel in forward or reverse.
- Reel Tubing Lubrication - A valve that meters lubrication to the oiler.

Couplings

- Table-1 Hose Connection Table (Refer to the Hydraulic/Pneumatic Schematic and Hose Kit)

DESCRIPTION	HOSE TAG #	DESCRIPTION	HOSE TAG #
Reel Brake	40	Reel Lubrication	66
Case Drain	85	Air Supply	68
Reel In	46	Levelwind Raise	90
Reel Out	45	Levelwind Lower	89
Levelwind Reverse	43	Circulation Pressure	41
Levelwind Forward	42		

Head spooler and level wind

Levelwind Raise/Lower Circuit

The levelwind raise/lower circuit is supplied with 2,500 PSIG From the levelwind power pack circuit. Pressure is directed to the “B” bank of a 4-way, 3-bank valve. From there, it is directed to either end of the lifting cylinders (depending on raise or lower selection). A counterbalance valve located at the rear of the skid holds the levelwind in position in case of hydraulic power loss.

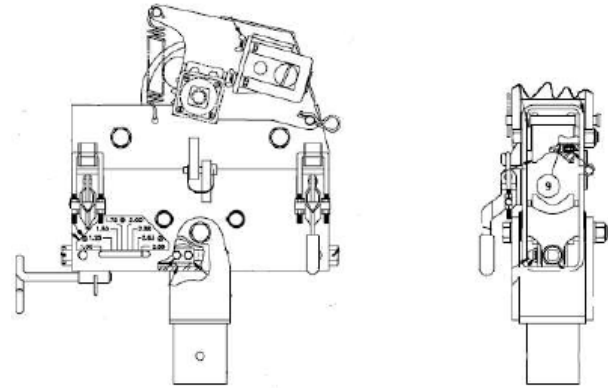

Levelwind Drive Circuit

The levelwind circuit is a continuous chain drive from a sprocket on the tubing reel drum to another sprocket on the levelwind arm with interchangeable sprockets for tubing size. A friction clutch is located in the hub of the sprocket on the leadscrew.

Levelwind Override

The levelwind override circuit receives its’ power from the power pack levelwind circuit. The maximum pressure from the pump is 2500 PSIG and the maximum flow is 28 GPM. The pressure is preset on relief valve mounted on the power pack. The levelwind motor is used by the operator to correct the track of the tubing when it is not winding correctly on the reel.

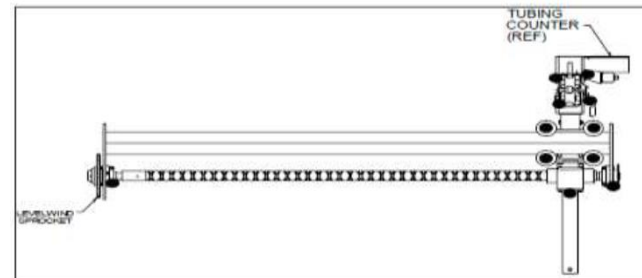

Reel Swivel

Reel Swivel Assembly

The design of the Hydra Rig swivel assembly allows the swivel to be a low maintenance component.

Follow the below instructions.

- Grease the bearings every 10 hours of operation.
- Tear down the swivel every 750 hours of operation and watch for leakage from weep hole.
- Replace visibly worn internal parts.
- Torque flange mounting nuts after every job.
- When rebuilding the swivel replace flange mounting lock washers.
- When rebuilding the swivel replace the front reel shaft seal.
- When rebuilding the swivel replace the front reel shaft seal.
- When pumping acids, use an inhibitor. Use a neutralizer when possible.
- Always drain the swivel after completing your job to reduce the chances of pitting.
- When rebuilding the swivel, change the grease zerk. Inspect every month to ensure it has not been damaged.

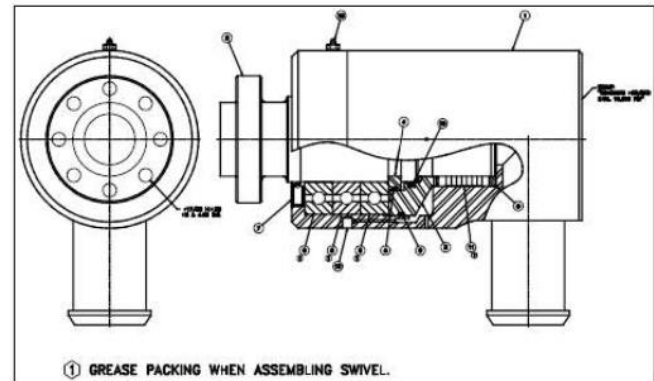

Spooler



BOP & Tubing Hanger



Mud Equipment



Batch Mixer Trailer



TRS Equipment



Under Balance Equipment

